

Trends and Technology: Spring 2004

.....
MARY JANE GORE
.....

Trends and Technology welcomes releases and information about new products, services, Web sites, trends, and upcoming events (give us six months lead time for seminars and meetings). If your company has a Website that you would like for us to review, please send us news for our Online section, or tell us about sites that would interest clinical laboratory scientists. These sites, as well as the new product information, are offered for reader information only. We cannot vouch for them and their presence here does not constitute an endorsement by CLS or ASCLS.

FDA APPROVALS

Dade Behring has received clearance from the U.S. Food and Drug Administration (FDA) for use of its N High Sensitivity CRP assay as an independent risk marker for the identification of individuals at risk for future cardiovascular disease, i.e., risk assessment. When used in conjunction with tradi-

.....
The Trends and Technology section seeks to publish product and technology information (including black-and-white glossy photographs), news items (such as FDA approvals), and information about laboratory resources of all kinds. The intent of this section is to provide a cutting-edge, one-stop shop tailored to the current practical needs and concerns of clinical laboratory practitioners. Let us hear from you with suggestions on how to improve this section. Direct inquiries and information to Mary Jane Gore, CLS Trends and Technology Editor, c/o ASCLS, 6701 Democracy Blvd., Suite 300, Bethesda, MD 20814, clstt@aol.com. Please send all materials clearly marked NEW PRODUCTS.

tional clinical laboratory evaluation of acute coronary syndromes, N High Sensitivity CRP measurements may also be useful as an independent marker of prognosis of recurrent events in patients with stable coronary disease or acute coronary syndromes, i.e., risk stratification. An expert panel of the Centers for Disease Control and Prevention concluded that for patients with stable coronary disease or acute coronary syndromes, high sensitivity CRP measurement may be useful as an independent marker for assessing likelihood of recurrent events. For more information, contact Melissa Ziriakus (847) 236-7038.

NEW PRODUCTS

Quantimetrix Corporation releases GlycoHemosure, its new hemoglobin A1c control. This control is intended as a reference material for the monitoring of serum hemoglobin A1c. This product is supplied as a ready use liquid requiring no reconstitution and is prepared from human serum. Quantimetrix provides a comparative quality control program called Quantrol™ which is available for its products. Contact Monica Jacobs (310) 536-0006, x 154.

HemoGenix has introduced the HALO® Platform to provide the biotechnology and pharmaceutical industry with a rapid, high-throughput, multifunctional hemotoxicity testing system which can be used at all stages of drug development from screening to clinical trials. Based on the classical semi-solid colony-forming procedure, HALO® is a proliferation assay with non-subjec-

tive luminescence readout. HemoGenix has now completed development and release of its proprietary HALO® Kit platform allowing individual researchers to perform hematopoietic/hemotoxicity testing in their own laboratories. Contact (719) 264-6250 or email halokitsales@hemogenix.com; visit www.hemogenix.com.

New Supor EKV 0.2 micron sterilizing grade filters from Pall Corporation are designed for the economical filtration of buffers, biologicals, tissue culture media, ophthalmic products, and many other biopharmaceutical fluids. These unique polyethersulfone membrane filters contain a built-in pre-filter layer that has been developed with Pall's machV technology, a proprietary asymmetrical V-shaped funnel-like pore structure that increases throughput to extend filter life. Contact Paul Hendley of AB Isacson at (212) 529-4500, x 205.

Researchers at the Pacific Northwest Research Institute (PNRI) have reported the development of a blood test for mesothelioma, a highly aggressive lung cancer caused by asbestos exposure. The new test promises a simple technique for diagnosing and monitoring mesothelioma early in its progress, when therapy is more likely to be successful. Fujirebio Diagnostics Inc (FDI) of Malvern PA, a leading oncology diagnostic company, has acquired an exclusive license from PNRI to develop a commercial test for worldwide distribution. For more information, see www.pnri.org.

To enhance laboratory efficiency and provide customers with the means to achieve higher levels of quality management and regulatory compliance, Mettler Toledo announces the addition of LabX Balance to its popular LabX software platform. With LabX Balance, traditional paper-based weighing processes can be replaced with a more powerful, efficient, and secure networked data system. LabX Balance saves time, uniquely tracks user and balance data and meta-data, and reduces mistakes. Mettler Toledo has also introduced next-generation benchtop meters for pH, conductivity, and ions. All meters include a robust electrode support arm that can stand alone or connect to the meter in two positions. For more information, contact Sheila St. Jean at 614-438-4936.



Mettler Lab AX DL 50L

Laboratories At Bonfils (L.A.B.) in Denver now offer the Procleix[®] HIV-1/HCV Assay, a nucleic acid test (NAT), for organ and tissue donor testing in living and cadaveric donors. The Procleix Assay utilizes transcription-mediated amplification technology, making it a highly specific and sensitive test. This assay is an in-vitro nucleic acid test for the detection of human immunodeficiency virus type 1 and hepatitis C virus in whole blood donors, source plasma, and most recently, living organ donors. When employed in screening donated blood, the Procleix HIV-1/HCV test has been shown to reduce the window period

between infection and detection for HIV-1 by 50 percent and for HCV by 70 percent. For more information, visit www.labsatbonfils.com.

Colder Products Company (CPC) announces the global launch of a new set of panel mount coupling bodies for its APC product line. The new configuration provides added flexibility and mounting options to create secure connections for applications that include water filtration, distillation equipment, and analytical instrumentation. CPC offers 14 different configurations of the APC panel mount body, both valved and non-valved. Terminations include several sizes of hose barbs and CPC's ferruleless polytube compression fitting. For information, contact Patrick Williams, pat.williams@colder.com.

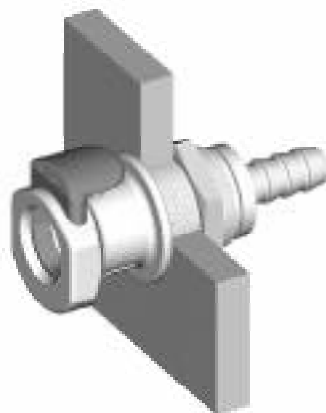

APC panel mount

Pickering Laboratories has reported results of an R&D effort that will raise standards industry-wide by advancing the ability to detect chemical compounds during HPLC analysis. Hyperion Post-Column Derivatization System builds on the success of the Pickering PCX5200 with unsurpassed precision for selectively separating and detecting analytes. Pickering Laboratories is the only company in the

HPLC industry focused entirely on post-column systems, chemistries, methods, and software for the analytical market. Pickering systems enable HPLC analysis of difficult to detect compounds very specifically and reproducibly. For more on this product, visit http://www.pickeringlabs.com/catalog/IH_pcx5200.php4.

Bayer's Diagnostics Division has expanded its BNP assay offering by launching it on the ACS:180 Immunoassay System. The assay is an automated test used as an aid in diagnosing heart failure and was cleared for marketing in 22003. Contact (914) 631-8000.

NCCLS announces several new documents for laboratory operations: quality control of microbiological transport systems (NCCLS document M40-A); methods for antimicrobial susceptibility testing of anaerobic bacteria (M11-A6); performance standards for antimicrobial susceptibility testing (M100-S14); total error estimator (EP21-A-C); and data content for specimen identification (refers to bar codes; AUTO7-P). Purchase these through NCCS at www.nccls.org or call (610) 688-0100.

ONLINE

Franek Technologies has launched its improved Website to assist laboratories in putting power protection safeguards in place to protect critical data from corruption or complete loss. Laboratory scientists can learn firsthand what is needed to protect their clinical instruments, down to the exact model number. Visit www.franek-tech.com.