

Molecular Action of ADAMTS13 and Transfusion Therapies of Thrombotic Thrombocytopenic
Purpura

Abstract:

Thrombotic Thrombocytopenic Purpura (TTP) is a disease that is classified by abnormal functioning of the ADAMTS13 protease. ADAMTS13 protease impairment can be caused by genetic mutations at the gene level or through autoantibodies that are formed within the circulation. Congenital mutations account for about 5-10% of the TTP population while the acquired version is more common. The acquired version of TTP is due to inhibitory and non-inhibitory autoantibodies that affect the ADAMTS13 protease. Both congenital and acquired TTP are treated through transfusion therapy with therapeutic plasma exchange (TPE). TPE is used to remove the autoantibodies and any mutated ADAMTS13 proteases in the circulation while providing the addition of normal functioning ADAMTS13 to the circulation.

Objectives:

1. Explain normal ADAMTS13 functioning in the plasma.
2. Describe the abnormal functioning of ADAMTS13 in congenital and acquired Thrombotic Thrombocytopenic Purpura
3. Describe the mechanism of transfusion therapy for Thrombotic Thrombocytopenic Purpura.

Abbreviations:

ADAMTS13 - a disintegrin and metalloproteinase with a thrombospondin type 1 motif, member 13, CPP - plasma cryoprecipitate reduced, FFP - fresh frozen plasma, FP24 - plasma frozen within 24 hours after phlebotomy, IgG - immune globulin G, IgM - immune globulin M, LDH - lactic acid dehydrogenase, TP - thawed plasma, TPE - therapeutic plasma exchange, TTP - Thrombotic Thrombocytopenic Purpura, ULVWF - ultra-large von Willebrand factor, VWF – von Willebrand factor

Index terms: ADAMTS13, autoantibodies, IgG, thrombotic thrombocytopenic purpura,
therapeutic plasma exchange

Introduction

Thrombotic Thrombocytopenic Purpura (TTP) is the common term for patients who present with thrombocytopenia and microthrombi formation in the small capillaries. These thrombotic microangiopathies may be seen in adults with or without predominant neurologic symptoms. TTP may occur at any age; however, the peak incidence is in the third decade of life.¹ TTP clinically presents similarly to other thrombotic microangiopathies, and often requires a diagnosis through exclusion. Classic TTP shows symptoms of hemolytic anemia, thrombocytopenia, neurologic symptoms, and fever. Early intervention is essential for patients presenting with TTP as untreated mortality rates are approximately 90%. Treated mortality rates decrease drastically to 10-20%.² At the vascular level, TTP is a disease with a deficiency of a disintegrin and metalloproteinase with a thrombospondin type 1 motif, member 13 (ADAMTS13) that results in accumulation of ultra-large von Willebrand Factor (ULVWF) which drives activation of intravascular platelets resulting in microvasculature thrombi.³ ULVWF multimers are formed in large strings in the endothelium and are anchored to the cell wall. These multimers are extremely adhesive to platelet glycoproteins, causing platelet aggregation.⁴

ADAMTS13

ADAMTS13 is encoded by the *ADAMTS13* gene located on chromosome 9q34 where it is comprised of 29 exons and covers approximately 37kb on chromosome 9.^{5,6} The basic structure of ADAMTS13 includes a metalloproteinase (proteolytic domain), thrombospondin-1 like domains (TSP) for a total of 8 domains, a cysteine-rich/spacer motif, and two CUB (for complement C1r/C1s, Uegf, Bmp1) structures (peptide containing domains). The N-terminal

includes the metalloproteinase, disintegrin, TSP1, and the cysteine-rich/spacer. The C-terminal includes the TSP2-8 domains and the two CUB structures⁴ (Figure 1). ADAMTS13 is synthesized in the hepatic stellate cells of the liver and to lesser extent endothelial cells. ADAMTS13 is secreted into circulation as an active enzyme, different from other ADAMTS proteases, and results in a precursor protein that is 1427 amino acids in length (approximately 145-kD).^{5,6} Further processing of the ADAMTS13 transcripts are complex and varied. In the plasma, there have been several forms of ADAMTS13 transcripts isolated including 170, 160, and 120-kD proteins that contain an N-terminal amino acid sequence that is identical in all forms.⁵ In an active state, ADAMTS13 is a folded protein where the CUB domains interact with the spacer region of the proteinase.⁷

When normal functioning is observed, ADAMTS13 protease cleaves von Willebrand factor (VWF) between Tyrosine 1605 and Methionine 1606 in A2 domain of the VWF protein; this results in a mature VWF protein. The main target of this cleavage is the ULVWF molecules that are the precursor of mature VWF. During high shear events, ULVWF unfolds, exposing the A2 site to the ADAMTS13 protease for cleavage. Deficiency in ADAMTS13 protease allows for ULVWF to remain uncleaved in the vasculature, resulting in the aggregation of micro clots. ADAMTS13 protease deficiencies can be seen in cases of a genetic mutation (homozygous or heterozygous) or autoimmune inhibitors of the circulating protease.⁸ Under normal conditions, ADAMTS13 circulates at a concentration of 1 ug/ml with a plasma half-life of 2-3 days.⁶

Genetic Mutations and Congenital TTP

When a mutation occurs at the gene site, the result is an absence or deficiency of ADAMTS13 protease.¹ At the time of publication there were over 70 identified mutations in the *ADAMTS13*

gene resulting from various missense, nonsense, frame shift, or splice site mutations.² Each mutation class affects a different portion of the gene's coding region impairing different variations of gene synthesis, secretion, or proteolytic activity.⁶ The result of a genetic mutation results in congenital (familial) TTP and rarely has an autoimmune component to the disease presentation.⁴

Congenital TTP is a relapsing disorder where patients have less than 5-10% of normal plasma ADAMTS13 levels and accounts for 5% of TTP cases. For these patients, their ADAMTS13 levels remain in that range during and between thrombotic episodes. Congenital TTP is caused by an autosomal recessive inheritance of homozygous or double heterozygous mutations in the *ADAMTS13* gene. TTP episodes usually begin in infancy/childhood and continue throughout the patient's life.⁴ Compound heterozygous mutations account for 65% of familial cases with the remaining 35% caused by homozygous mutations in the gene's coding region.

Inhibitors and Acquired TTP

Autoimmune inhibitors of the ADAMTS13 protease are responsible for 95% of all TTP cases and that inhibition is known as acquired TTP.⁶ The antibody response includes inhibitory and non-inhibitory antibodies. The inhibitory antibodies block the proteolytic activity of ADAMTS13 toward VWF and the non-inhibitory antibodies aid in increasing ADAMTS13 clearance from the patient's circulation. The principle antibody class for acquired TTP is IgG with a minor class of IgM and IgA antibodies present in cases.^{6,8} Of the IgG class molecules, IgG1 and IgG4, molecules that differ only in their Fc regions, are the predominant IgG antibodies present. IgG1 antibodies are found most common in the beginning stages of acquired TTP and with the first acute episode of the disease, while IgG4 antibodies can found in cases of

prolonged stimulation and are common in later stages of acquired TTP.⁹ While IgM antibodies are less common, one study showed that the presence of IgM antibodies in the circulation resulted in an overall increase (35-79%) in ADAMTS13 activity as compared to less than 10% activity in the presence of IgG antibodies.¹⁰

Acquired TTP patients show transient inhibition of ADAMTS13 with levels less than 5-10% during acute thrombotic episodes and etiologies are mostly unknown.^{4,11} During non-thrombotic events, ADAMTS13 activity may be in a normal range due to the natural decrease of inhibitors within the circulation.¹¹ During thrombotic events, autoantibodies formed will show affinity towards the specific metalloprotease and spacer domains of the ADAMTS13 transcript located on the N-terminal end.¹¹ In these events, ADAMTS13 appears in a more open configuration, exposing cryptic epitopes in the spacer region that are the site for autoantibody attachment. These epitopes have been described as R568, R660, Y661, and Y665 in multiple studies and are found in the spacer domain of the protease⁷ (Figure 2). This area of the gene is significant for proper protease function.¹¹ The determination between inhibitory and non-inhibitory antibodies in acquired TTP cases can only be determined through laboratory testing.

Transfusion Therapy for Acquired TTP

Treatment for both congenital and acquired TTP is the same, therapeutic plasma exchange (TPE). The purpose of TPE is to remove molecules from the plasma that are inhibitory or replace normal substances that may be missing from the circulation. The molecules that can be removed include a variety of high-molecular weight complexes, antibodies, and proteins, while normal substance replacements can include coagulation factors or enzymes. In TTP, the goal of TPE is to perform both indications, remove inhibitory antibodies or non-functioning

ADAMTS13 molecules while replacing normal functioning ADAMTS13.³ TPE is a lengthy procedure that includes removing defective plasma from the circulation and replacing the volume with normal plasma and is a concurrent exchange of a person's total plasma volume. This process occurs by removing whole blood from the circulation, extracting the plasma, and returning the remaining blood products with the new plasma back to the circulation.

Active ADAMTS13 can be found in many different plasma products including fresh frozen plasma (FFP), plasma frozen within 24 hours after phlebotomy (FP24), or plasma cryoprecipitate reduced (CPP). Once the frozen plasma product has been thawed, it is considered thawed plasma (TP). Plasma products can be prepared from a whole blood donation or a plasma apheresis procedure. Once collected, there are different storage and preparation techniques that can be used. In most cases, the plasma product is frozen quickly to maintain coagulation factor activity. FFP is the name given to a plasma product that has been frozen within 8 hours of collection and processing. FP24 is a plasma product that has been frozen within 24 hours of collection and processing. CPP is the plasma byproduct of cryoprecipitate preparation. When cryoprecipitate is removed from plasma, the remaining plasma is frozen within 24 hours to create CPP. Some coagulation factors are decreased in CPP compared to the other plasma products available. All frozen plasma products have a shelf life of 12 months once frozen and cannot be used clinically until they are thawed. TP is created when a frozen plasma of any form is thawed for use. TP has a shelf-life of 5 days once thawed and can be used in all clinical situations. ADAMTS13 levels are maintained at normal levels in thawed plasma for the entire 5 days.²

The half-life of infused ADAMTS13 through plasma is 2-4 days, similar to the normal acting half-life of ADAMTS13.⁴ TPE is used as a front line treatment for multiple reasons: it is

easily accessible, can clear ADAMTS13 antibodies from the circulation, and it can add normal functioning ADAMTS13 back into the circulation. There can be adverse effects associated with TPE, the same as any transfusion. Some noted adverse effects of TTP include hypocalcemia due to the infusion of citrate with the returned blood, a burning or prickling sensation (paresthesia), and occasionally nausea.³ Over time, CPP may be a better option for TPE due to the fact that CPP contains fewer high-molecular weight VWF multimers than standard FFP.²

The normal course of TPE for an acquired TTP case is five to seven days of treatment. Each day of treatment removes a portion of the autoantibodies present in the circulation, replacing the removed volume with clinically active ADAMTS13. TPE works optimally when the antibody class is primarily IgG, found in the majority of acquired TTP cases. TPE may have to be extended if IgM antibodies are present or the platelet count does not increase above 150,000/uL.² If IgM is the primary antibody, it will take longer to remove from the plasma due to the size of the antibody. One IgM molecule is 5 times the size of an IgG antibody. Congenital TTP is treated on a more routine schedule of TPE allows for the removal of any ADAMTS13 antibodies, inhibitors, or additional VWF multimers.³ Continuous treatment of congenital TTP by TPE prevents thrombotic events. Suggested TPE protocols require 10-15 milliliter per kilogram body weight at intervals of two-three weeks.

The treatment of acquired TTP consists of daily TPE with a volume of 1-2 times the patients' blood volume, approximately 40-60 milliliter per kilogram body weight. This is continued until a platelet count at or above 150,000/uL is observed for 2-3 days, the lactate dehydrogenase (LDH) normalizes, and any neurologic side effects subside. LDH is commonly seen elevated in thrombotic TTP episodes due to intravascular hemolysis. The red blood cells in the microcirculation release LDH in these events. LDH values will normalize as red blood cell

hemolysis decreases. After stabilization in laboratory results, TPE can be administered every other day if needed.^{1,4} Laboratory values for a typical course of TPE show platelet counts rising and LDH values decreasing until a normalized state is observed (Table 1).

Platelet transfusions are not a treatment option for TTP, even though thrombocytopenia is present. As we reviewed, in TTP cases, platelets interact with ULVWF to create micro thrombi within the circulation. This can lead to a drastic decrease in platelets in circulation. The addition of new platelets through transfusion could increase the thrombotic events without removing the ADAMTS13 inhibitor prior to transfusion.²

Presently, there are a few recombinant drug options available to aid in treatment of TTP. One new recombinant product that is being examined Caplacizumab, an anti-VWF nanobody.¹²

Table 1 shows the laboratory values of a 40 year old female who presented to the emergency room with TTP symptoms. Patient is known to have acquired TTP prior to this visit. The patient underwent daily TPE for a course of 6 days at 3000ml plasma volume the first three days and 3500ml plasma exchange the next three days. Plasma exchange volume was appropriately dosed based on that patient's body weight and was increased on day 4 to better her platelet response. On day 6 of treatment, the patient's platelets had reached the appropriate threshold of above 150 bil/L and LDH were within normal ranges. Patient was discharged on day 7 without complication.

Conclusion

TTP is a disease that can be the result of a genetic mutation in or an acquired antibody to the ADAMTS13 protease molecule. ADAMTS13 is essential for preventing microthrombi in the circulation and both branches of TTP change the normal functioning of ADAMTS13. A standard

treatment for TTP includes rounds of TPE to remove the antibodies and inhibitors that may be found in the circulation of patients with TTP. By removing the antibodies in circulation, ADAMTS13 is able to cleave VWF as expected and prevent platelet aggregation that leads to the micro thrombi.

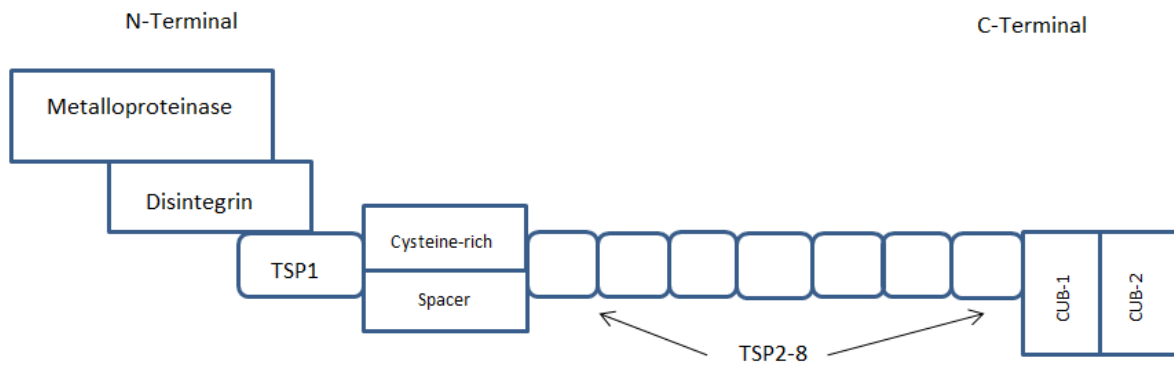

Figure 1. Domain structure of ADAMTS13. ADAMTS13 is comprised of a metalloproteinase (proteolytic domain), thrombospondin-1 like domains (TSP) for a total of 8 domains, a cysteine-rich/spacer motif and two CUB structures (peptide containing domains). The N-terminal domain of ADAMTS13 is comprised of the metalloproteinase, disintegrin, TSP1, and the cysteine-rich/spacer domains. The C-terminal domains include TSP2-8 and the two CUB structures.

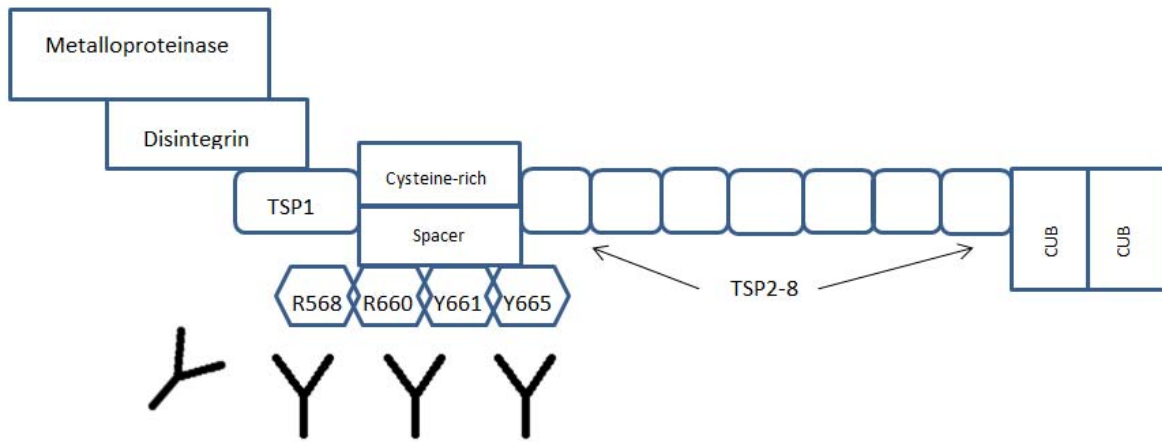

Figure 2. Cryptic epitopes in the spacer domain that are targeted by autoantibodies to ADAMTS13.

Table 1: 40 year old female undergoing treatment TPE for TTP. Treatment was a 6 day course of plasma exchange at 10-15 milliliter/kilogram body weight. During treatment, platelets values and LDH values were closely monitored. Platelet values steady increased throughout treatment while LDH values decreased to within normal range.

Hematology:	Reference Range	Original lab results (Day 1):	Day 2	Day 3
Platelet bil/L	150-400	32	22	37
Chemistry:				
LDH U/L	100-240	362	240	190
Blood Bank:				
Plasma Volume Exchange		0 ml	3000 ml	3000 ml
Hematology:	Day 4	Day 5	Day 6	Day 7 (After TPE)
Platelet bil/L	91	112	175	195
Chemistry:				
LDH	176	159	147	152
Blood Bank:				
Plasma Volume Exchange	3000 ml	3500 ml	3500 ml	3500 ml

References

1. McPherson RA, Pincus MR. Henry's Clinical Diagnosis and Management by Laboratory Methods. 21st Edition. Elsevier;2007.
2. Mintz P, editor. Transfusion Therapy-Clinical Principles and Practices. 3rd Edition. AABB Press;2011.
3. Davenport RD. Therapeutic Apheresis. In: Fung M, Grossman B, Hillyer C, Westhoff C, editors. Technical Manual. 18th Edition. AABB Press;2014. p. 645-664.
4. Moake J. Thrombotic thrombocytopenia purpura (TTP) and other thrombotic microangiopathies. *Best Pract Res Clin Haematol.* 2009;22:567-576.
5. Tsai H. Why do we need ADAMTS13? *Nihon Kessen Shiketsu Gakkai shi.* 2005;16(1):54-69.
6. Ferrari S, Mudde GC, Reiger M, Veyradier A, Kremer Hovinga JA, Scheiflinger F. IgG subclass distribution of anti-ADAMTS13 antibodies in patients with acquired thrombotic thrombocytopenic Purpura. *J Throm Haemost.* 2009;7:1703-1710
7. Roose E, Vidarsson G, Kangro K, Verhagen O, Mancini I, Desender L, Pareyn I, Vandeputte N, Vandebulcke A, Vendramin C, Schelpe A, Vorrberg J, Azerad M, Gilardin L, Scully M, Dierickx D, Deckmyn H, De Meyer S, Peyvandi F, Vanhoorelbeke K. Anti-ADAMTS13 autoantibodies against cryptic epitopes in immune-mediated thrombotic thrombocytopenic purpura. *Thromb Haemost.* 2018;118:1729-1742.
8. James P, Rydz N. Structure, Biology, and Genetics of von Willabrand Factor. In: Hoffman R, Benz EJ, Silberstein LE, Heslop H, Anastasi J, Weitz, J, editors. *Hematology: Basic Principles and Practice.* 7th Edition. Elsevier;2018. p. 1987-1999.

9. Sinkovits G, Szilágyi Á, Farkas P, Inotai D, Szilvási A, Tordai A, Rázsó K, Réti M and Prohászka Z. Concentration and subclass distribution of anti-ADAMTS13 IgG autoantibodies in different stages of acquired idiopathic thrombotic thrombocytopenic purpura. *Front Immunol.* 2018;9:1646.
10. Rieger M, Mannucci P, Hovinga JA, Herzog A, Gerstenbauer G, Konetschny C, Zimmermann K, Scharrer I, Peyvandi F, Galbusera M, Remuzzi G, Böhm M, Plaimauer B, Lämmle B, Scheiflinger F. ADAMTS13 autoantibodies in patients with thrombotic microangiopathies and other immunomediated diseases. *Blood.* 2005;106(4):1262-1267.
11. Blombery P, Scully M. Management of thrombotic thrombocytopenic purpura: current perspectives. *J Blood Med.* 2014;5:15-23.
12. Peyvandi F, Scully M, Hovinga JA, Cataland S, Knöbl P, Wu H, Artoni A, Westwood JP, Taleghani MM, Jilma B, Callewaert F, Ulrichs H, Duby C, Tesago D. Caplacizumab for Acquired Thrombotic Thrombocytopenic Purpura. *N Engl J Med.* 2016;374:511-522.